

## EXPANSION CARD

Up to two expansion cards can be installed inside the L300P.

### Digital Input Expansion Card

SJ-DG

Output frequency, acceleration time, deceleration time, and torque limit can be set by a digital output device such as PLC, etc. (Binary or BCD)

#### Connecting Diagram

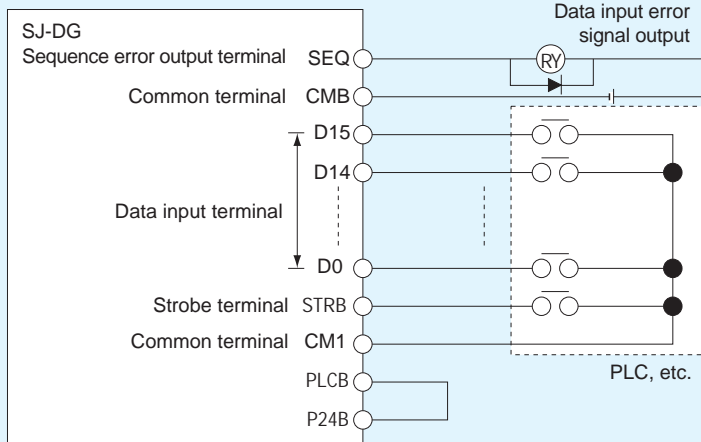

#### Data Bit Configuration

Item	Mode 1	Mode 2
D15	Data classification code	Setting data
D14		
D13		
D12		
D11		
D10		
D9		
D8		
D7	Setting data Data can be set by either 16-bit binary or 4-digit BCD.	Data can be set by either 16-bit binary or 4-digit BCD.
D6		
D5		
D4		
D3		
D2		
D1		
D0		

[ Input data is divided into upper 8-bit and lower 8-bit. ]

\*Data input mode is selected by the dip switch on the expansion card.

#### Standard Specifications

Item	Specification
Input	Data setting signal Strobe signal
Output	Sequence error signal (Data input error signal)
Power supply	Power supply for interface
	NO contact input (sink/ source compatible)
	Open collector output (sink/ source compatible)
	DC+24V 90mA max., between P24B and CM1
	D0,D1, ... between D15 and PLCB
	Between STRB and PLCB
	DC+27V 50mA max., between SEQ and CMB

### DeviceNet™ Expansion Card

SJ-DN

#### Specifications

General data	Applicable DeviceNet specification	
	Volume 1-Relesse 2.0	Volume 2-Relesse 2.0
Vendor name	Hitachi, Ltd.	Vendor ID=74
Device profile name	Slave DC Drive	Profile No.=13
Network consumption current	50mA	
Connector type	Open connector	
Isolation of physical layer	Yes	
Support LED	Module status / network status	
MAC ID setting	By digital operator	
Default MAC ID	63	
Transmission baud rate setting	By digital operator	
Support transmission baud rate	125k/250k/500k	
Pre-defined master/slave connection set	Group 2 only server	
UCMM Support	None	
Support connection	Explicit message connection, Polled I/O connection	
Explicit message fragmentation	Yes	

#### Connector specifications

Manufacturer	Model Code
Phoenix Contact	MSTB 2.5/5-ST-5.08AU

#### Cable connection

No	Signal	Cable color
1	V-	Black
2	CAN_L	Blue
3	Drain	-
4	CAN_H	White
5	V+	Red

#### Dimensional drawings [Unit:mm]

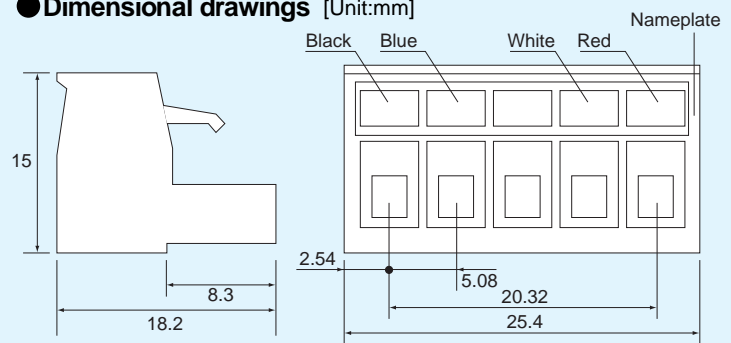

Note: Communication power supply (24VDC) is required in system configuration.

DeviceNet is a trademark of Open DeviceNet Vendor Association.

Item		400V Class										
Model L300P-XXX	UL version	015HFU2	022HFU2	040HFU2	055HFU2	075HFU2	110HFU2	150HFU2	185HFU2	220HFU2	300HFU2	
	CE version	015HFE2	022HFE2	040HFE2	055HFE2	075HFE2	110HFE2	150HFE2	185HFE2	220HFE2	300HFE2	
Enclosure (*2)		IP20 (NEMA 1) (*1)										
Applicable motor (4-pole, kW(HP)) (*3)		1.5(2)	2.2(3)	4.0(5)	5.5(7.5)	7.5(10)	11(15)	15(20)	18.5(25)	22(30)	30(40)	
Rated capacity (kVA)	400V	2.6	3.6	5.9	8.3	11	15.2	20.0	25.6	29.7	39.4	
	480V	3.1	4.4	7.1	9.9	13.3	18.2	24.1	30.7	35.7	47.3	
Rated input voltage		3-phase (3-wire) 380-480V (±10%), 50/60Hz										
Rated input current (A)		4.2	5.8	9.5	13	18	24	32	41	47	63	
Required power supply capacity (kVA)		3	4.4	8	11	15	22	30	37	44	60	
Rated output voltage (*4)		3-phase (3-wire) 380-480V (Corresponding to input voltage)										
Rated output current (continuous)(A)		3.8	5.3	8.6	12	16	22	29	37	43	57	
Control method		Line to line sine wave PWM										
Output frequency range (*5)		0.1-400Hz										
Frequency accuracy		Digital: ±0.01% of the maximum frequency, Analog: ±0.2%(25±10°C)										
Frequency resolution		Digital setting: 0.01Hz, Analog setting: (Maximum frequency)/4,000 (0 terminal: 12-bit 0-10V, 02 terminal: 12-bit -10-+10V)										
V/f characteristics		V/f optionally variable, V/f control (Constant torque, reduced torque)										
Overload capacity		120% for 60sec., 150% for 0.5sec.										
Acceleration/deceleration time		0.01-3,600sec. (Linear/curve, accel./decel. selection), Two-stage accel./decel.										
Braking	Dynamic braking (Short-time) (*6)	Built-in BRD circuit(optional resistor)							External dynamic braking unit (option)			
	DC braking	Performs at start; under set frequency at deceleration, or via an external input (braking force, time, and operating frequency).										
Input signal	Frequency setting	Operator	Up and Down keys									
		Potentiometer	Potentiometer									
		External signal	DC 0-10V, -10-+10V (input impedance 10kΩ), 4-20mA (input impedance 100Ω)									
		External port	RS-485 interface									
	Forward/reverse	Operator	Run key/Stop key (FW/RV can be set by function command.)									
		External signal	FW RUN/STOP (NO contact), RV set by terminal assignment (NO/NC selection), 3-wire input available									
	Start/stop	External port	Set by RS-485									
	Intelligent input terminals (Assign five functions to terminals)	RV(Reverse), CF1-CF4(Multispeed command), JG(Jogging), DB(External DC braking), SET(Second motor constants setting), 2CH(Second accel./decel.), FRS(Free-run stop), EXT(External trip), USP(Unattended start protection), CS(Change to/from commercial power supply), SFT(Software lock), AT(Analog input selection), RS(Reset), STA(3-wire start), STP(3-wire stop), F/R(3-wire fwd./rev.), PID(PID On/Off), PIDC(PID reset), UP/DWN(Remote-controlled accel./decel.) UDC(Remote-controlled data clearing), SF1-SF7(Multispeed bit command 1-7), OLR(Overload limit change), ROK(RUN Permissive) and NO(Not selected)										
Thermistor input	One terminal(PTC)											
Output signal	Intelligent output terminals	Assign three functions to two NO contacts and one NO-NC combined contact (RUN, FA1, FA2, OL, OD, AL, FA3, IP, UV, RNT, ONT RMD and THM)										
	Intelligent monitor output terminals	Analog voltage, analog current, PWM output										
Display monitor		Output frequency, output current, scaled value of output frequency, trip history, I/O terminal condition, input power, output voltage										
Other user-settable parameters		V/f free-setting (up to 7 points), frequency upper/lower limit, frequency jump, accel./decel. curve selection, manual torque boost value and frequency adjustment, analog meter tuning, starting frequency, carrier frequency, electronic thermal protection level, external frequency output zero/span reference, external frequency input bias start/end, analog input selection, retry after trip, reduced voltage soft start, overload restriction, automatic energy-saving										
Carrier frequency range		0.5-12kHz										
Protective functions		Over-current protection, overload protection, braking resistor overload protection, over-voltage protection, EEPROM error, under-voltage error, CT(Current transformer) error, CPU error, external trip, USP error, ground fault, input over-voltage protection, instantaneous power failure, option 1 connection error, option 2 connection error, inverter thermal trip, phase failure detection, IGBT error, thermistor error										
Environmental conditions	Ambient operating /storage temperature(*7)/humidity	-10-40°C(*9) / -20-65°C / 25-90%RH (No condensation)										
	Vibration (*8)	5.9m/s <sup>2</sup> (0.6G), 10-55Hz										
	Location	Altitude 1,000m or less, indoors (no corrosive gases or dust)										
Color		Blue										
Options		EMI filters, input/output reactors, DC reactors, radio noise filters, braking resistors, braking units, LCR filter, communication cables, Network interface cards										
Operator		OPE-SR(4-digit LED with potentiometer) / OPE-SRE(4-digit LED with potentiometer, English overlay) Optional: OPE-S(4-digit LED), SRW-0EX(Multilingual (English,French, German, Italian, Spanish, and Portuguese) operator with copy function), ICS-1,3(Cable for operators(1m, 3m))										
Weight kg (lbs.)		3.5 (7.7)	3.5 (7.7)	3.5 (7.7)	3.5 (7.7)	5 (11)	5 (11)	5 (11)	12 (26.4)	12 (26.4)	12 (26.4)	

\*1: Up to 30kW.

An optional conduit box is required for 37kW to 55kW to meet NEMA 1.

\*2: The protection method conforms to JEM 1030 / NEMA(U.S.).

\*3: The applicable motor refers to Hitachi standard 3-phase motor (4-pole).

To use other motors, care must be taken to prevent the rated motor current (50Hz) from exceeding the rated output current of the inverter.

\*4: The output voltage decreases as the main power supply voltage decreases except for the use of AVR function.

\*5: To operate the motor beyond 50/60Hz, please consult with the motor manufacturer about the maximum allowable rotation speed.

\*6: Braking resistor is not integrated in the inverter. Please install optional braking resistor or dynamic braking unit when large braking torque is required.

\*7: Storage temperature refers to the temperature in transportation.

\*8: Conforms to the test method specified in JIS C0040(1999).

\*9: When using the inverter from 40° to 50°C ambient, the output current of the inverter must be derated (see the next section on derating curves).

# STANDARD SPECIFICATIONS

Item		400V Class							
Model L300P-XXX	UL version	370HFU2	450HFU2	550HFU2	750HFU2	900HFU2	1100HFU2	1320HFU2	
	CE version	370HFE2	450HFE2	550HFE2	750HFE2	900HFE2	1100HFE2	1320HFE2	
Enclosure (*2)		IP20 (NEMA 1) (*1)				IP00			
Applicable motor (4-pole, kW(HP)) (*3)		37(50)	45(60)	55(75)	75(100)	90 (125)	110 (150)	132 (175)	
Rated capacity (kVA)	400V	48.4	58.8	72.7	93.5	110.8	135.0	159.3	
	480V	58.1	70.1	87.2	112.2	133.0	162.1	191.2	
Rated input voltage		3-phase (3-wire) 380–480V (±10%), 50/60Hz							
Rated input current (A)		77	94	116	149	176	215	253	
Required power supply capacity (kVA)		74	90	110	150	180	220	264	
Rated output voltage (*4)		3-phase (3-wire) 380-480V (Corresponding to input voltage)							
Rated output current (continuous)(A)		70	85	105	135	160	195	230	
Control method		Line to line sine wave PWM							
Output frequency range (*5)		0.1–400Hz							
Frequency accuracy		Digital: ±0.01% of the maximum frequency, Analog: ±0.2%(25±10°C)							
Frequency resolution		Digital setting: 0.01Hz, Analog setting: (Maximum frequency)/4,000 (0 terminal: 12-bit 0–10V, 02 terminal: 12-bit –10–+10V)							
V/f characteristics		V/f optionally variable, V/f control (Constant torque, reduced torque)							
Overload capacity		120% for 60sec., 150% for 0.5sec.							
Acceleration/deceleration time		0.01–3,600sec. (Linear/curve, accel./decel. selection), Two-stage accel./decel.							
Braking	Dynamic braking (Short-time) (*6)	External dynamic braking unit (option)							
	DC braking	Performs at start; under set frequency at deceleration, or via an external input (braking force, time, and operating frequency).							
Input signal	Frequency setting	Operator	Up and Down keys						
		Potentiometer	Potentiometer						
		External signal	DC 0–10V, –10–+10V (input impedance 10k $\Omega$ ), 4–20mA (input impedance 100 $\Omega$ )						
		External port	RS-485 interface						
	Forward/ reverse	Operator	Run key/Stop key (FW/RV can be set by function command.)						
		External signal	FW RUN/STOP (NO contact), RV set by terminal assignment (NO/NC selection), 3-wire input available						
	Start/stop	External port	Set by RS-485						
	Intelligent input terminals (Assign five functions to terminals)	RV(Reverse), CF1-CF4(Multispeed command), JG(Jogging), DB(External DC braking), SET(Second motor constants setting), 2CH(Second accel./decel.), FRS(Free-run stop), EXT(External trip), USP(Unattended start protection), CS(Change to/from commercial power supply), SFT(Software lock), AT(Analog input selection), RS(Reset), STA(3-wire start), STP(3-wire stop), F/R(3-wire fwd./rev.), PID(PID On/Off), PIDC(PID reset), UP/DWN(Remote-controlled accel./decel.) UDC(Remote-controlled data clearing), SF1-SF7(Multispeed bit command 1-7), OLR(Overload limit change), ROK(RUN Permission) and NO(Not selected)							
Thermistor input	One terminal(PTC)								
Output signal	Intelligent output terminals	Assign three functions to two NO contacts and one NO-NC combined contact (RUN, FA1, FA2, OL, OD, AL, FA3, IP, UV, RNT, ONT, RMD and THM)							
	Intelligent monitor output terminals	Analog voltage, analog current, PWM output							
Display monitor		Output frequency, output current, scaled value of output frequency, trip history, I/O terminal condition, input power, output voltage							
Other user-settable parameters		V/f free-setting (up to 7 points), frequency upper/lower limit, frequency jump, accel./decel. curve selection, manual torque boost value and frequency adjustment, analog meter tuning, starting frequency, carrier frequency, electronic thermal protection level, external frequency output zero/span reference, external frequency input bias start/end, analog input selection, retry after trip, reduced voltage soft start, overload restriction, automatic energy-saving							
Carrier frequency range		0.5–12kHz				0.5–8kHz			
Protective functions		Over-current protection, overload protection, braking resistor overload protection, over-voltage protection, EEPROM error, under-voltage error, CT(Current transformer) error, CPU error, external trip, USP error, ground fault, input over-voltage protection, instantaneous power failure, option 1 connection error, option 2 connection error, inverter thermal trip, phase failure detection, IGBT error, thermistor error							
Environmental conditions	Ambient operating /storage temperature(*7)/humidity	–10–40°C(*9) / –20–65°C / 25–90%RH (No condensation)							
	Vibration (*8)	2.9m/s <sup>2</sup> (0.3G), 10–55Hz							
	Location	Altitude 1,000m or less, indoors (no corrosive gases or dust)							
Color		Gray (Bezel for digital operator is blue)							
Options		EMI filters, input/output reactors, DC reactors, radio noise filters, braking resistors, braking units, LCR filter, communication cables, Network interface cards							
Operator		OPE-SR(4-digit LED with potentiometer) / OPE-SRE(4-digit LED with potentiometer, English overlay) Optional: OPE-S(4-digit LED), SRW-0EX(Multilingual (English, French, German, Italian, Spanish, and Portuguese) operator with copy function), ICS-1,3(Cable for operators(1m, 3m))							
Weight kg (lbs.)		20 (44)	30 (66)	30 (66)	30 (66)	60 (132)	60 (132)	80 (176)	

\*1: Up to 30kW.

An optional conduit box is required for 37kW to 55kW to meet NEMA 1.

\*2: The protection method conforms to JEM 1030 / NEMA(U.S.).

\*3: The applicable motor refers to Hitachi standard 3-phase motor (4-pole).  
To use other motors, care must be taken to prevent the rated motor current (50Hz) from exceeding the rated output current of the inverter.

\*4: The output voltage decreases as the main power supply voltage decreases except for the use of AVR function.

\*5: To operate the motor beyond 50/60Hz, please consult with the motor manufacturer about the maximum allowable rotation speed.

\*6: Braking resistor is not integrated in the inverter. Please install optional braking resistor or dynamic braking unit when large braking torque is required.

\*7: Storage temperature refers to the temperature in transportation.

\*8: Conforms to the test method specified in JIS C0040(1999).

\*9: When using the inverter from 40° to 50°C ambient, the output current of the inverter must be derated (see the next section on derating curves).

# ACCESSORIES

## ● OPERATOR

Model	Potentiometer	Remote Control	Installation in L300P	Copy Function	Multilingual
OPE-S		○	○		
OPE-SR/SRE	○	○	○ (Standard for L300P)(OPE-SRE: Standard for L300P UL version)		
SRW-0EX		○	○	○	○

\*OPE-SRE: English overlay

## ● CABLE FOR OPERATOR

Model	Cable Length
ICS-1	1m (3.3ft)
ICS-3	3m (9.8ft)

## ■ REMOTE OPERATOR SRW-0EX(Optional)



## ■ DIMENSIONS

[Unit:mm (inch)]  
Inches for reference only

### ● OPE-S(R)

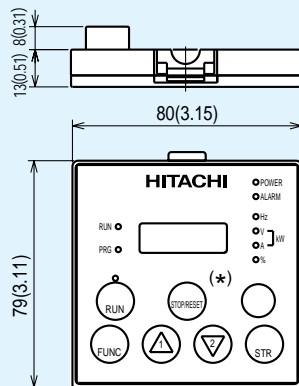

\*Potentiometer is installed only in ORE-SR/SRE.

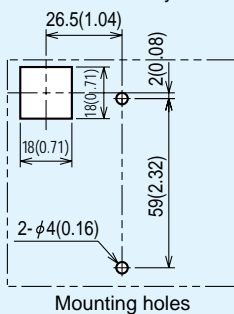

### ● SRW-0EX

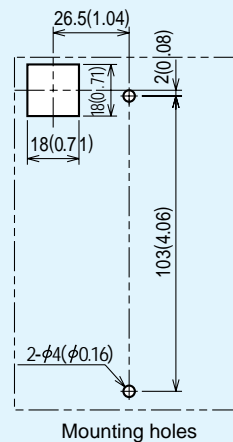
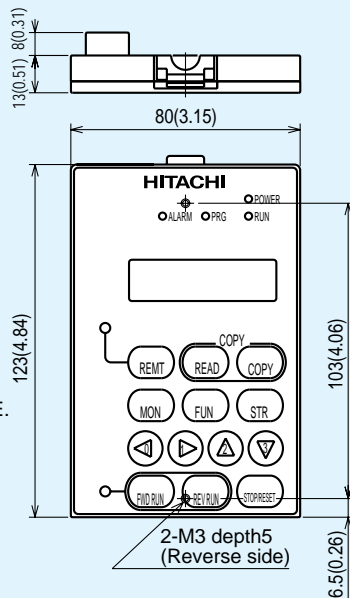

### ● ICS-1, 3

(Cables for OPE-S/SR/SRE and SRW-0EX)

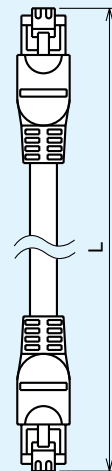

Model Name	Cable Length
ICS-1	1m (3.3ft)
ICS-3	3m (9.8ft)

# WIRING and ACCESSORIES

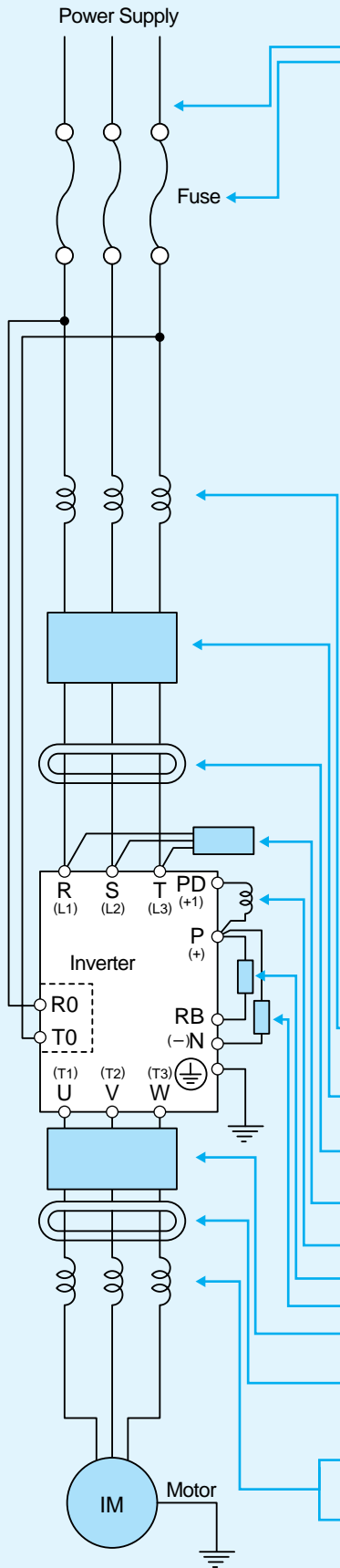

Input Voltage	Motor Output (kW(HP))	Model	Wiring		Signal Lines	Fuse (Class J)
			Power Lines			
			AWG	mm <sup>2</sup>		
200V	1.5(2)	L300P-015LFU2	AWG 14	2.1	0.75mm <sup>2</sup> shielded wire	10
	2.2(3)	L300P-022LFU2	AWG 14	2.1		15
	3.7(5)	L300P-037LFU2	AWG 10	5.3		20
	5.5(8)	L300P-055LFU2	AWG 8	8.4		30
	7.5(10)	L300P-075LFU2	AWG 6	13.3		40
	11(15)	L300P-110LFU2	AWG 4	21.2		60
	15(20)	L300P-150LFU2	AWG 2	33.6		70
	18.5(25)	L300P-185LFU2	AWG 4 *2	21.2 *2		90
	22(30)	L300P-220LFU2	AWG 1/0	53.5		100
	30(40)	L300P-300LFU2	AWG 2 *2	33.8 *2		150
	37(50)	L300P-370LFU2	AWG 1 *2	42.4 *2		175
	45(60)	L300P-450LFU2	AWG 1 *2(75°C)	42.4 *2		200
	55(75)	L300P-550LFU2	AWG 2/0 *2	67.4 *2		250
	75(100)	L300P-750LFU2	AWG 3/0 *2	85.0 *2		300
400V	1.5(2)	L300P-015HFU2	AWG 18	0.8	0.75mm <sup>2</sup> shielded wire	10
	2.2(3)	L300P-022HFU2	AWG 16	1.3		10
	3.7(5)	L300P-040HFU2	AWG 14	2.1		15
	5.5(8)	L300P-055HFU2	AWG 12	3.3		15
	7.5(10)	L300P-075HFU2	AWG 10	5.3		20
	11(15)	L300P-110HFU2	AWG 8	8.4		30
	15(20)	L300P-150HFU2	AWG 6	13.3		35
	18.5(25)	L300P-185HFU2	AWG 6	13.3		50
	22(30)	L300P-220HFU2	AWG 4	21.2		50
	30(40)	L300P-300HFU2	AWG 3	26.7		70
	37(50)	L300P-370HFU2	AWG 4 *2	21.2 *2		80
	45(60)	L300P-450HFU2	AWG 1	42.4		100
	55(75)	L300P-550HFU2	AWG 2 *2	33.8 *2		125
	75(100)	L300P-750LFU2	AWG 1 *2	42.4 *2		150
90(125)	L300P-900LFU2	AWG 1 *2(75°C)	42.4 *2	200		
110(150)	L300P-1100LFU2	AWG 2/0 *2	67.4 *2	225		
132(175)	L300P-1320LFU2	AWG 2/0 *2	67.4 *2	300		

Note 1: Field wiring connection must be made by a UL and c-UL listed closed-loop terminal connector sized for the wire gauge involved. Connector must be fixed using the crimping tool specified by the connector manufacturer.  
 Note 2: Be sure to use bigger wires for power lines if the distance exceeds 20m(66ft).

Name	Function
Input side AC reactor	This is useful in suppressing harmonics induced on the power supply lines, or when the main power voltage imbalance exceeds 3% (and power source capacity is more than 500kVA), or to smooth out line fluctuations. It also improves the power factor.
EMI filter	This filter reduces the conducted noise in the power supply wiring between the inverter and the power distribution system. Connect it to the inverter primary (input side).
Radio noise filter	Electrical noise interference may occur on nearby equipment such as a radio receiver. This magnetic choke filter helps reduce radiated noise (can also be used on output).
Radio noise filter (Capacitive filter)	This capacitive filter reduces radiated noise from the main power wires in the inverter input side.
DC link choke	The choke suppresses harmonics generated by the inverter. However, it will not protect the input diode bridge rectifier.
Braking resistor	Braking components are useful for increasing the inverter's control torque for high duty-cycle (on-off) applications, and improving the decelerating capability.
Braking unit	
Output side noise filter	Reduces radiated noise from wiring in the inverter output side.
Radio noise filter	Electrical noise interference may occur on nearby equipment such as a radio receiver. This magnetic choke filter helps reduce radiated noise (can also be used on input).
AC reactor	This reactor reduces the vibration in the motor caused by the inverter's switching waveforms, by smoothing the waveforms to approximate commercial power quality. It is also useful when wiring from the inverter to the motor is more than 10m in length, to reduce harmonics.
LCR filter	Sine wave shaping filter for the output side.

Note: An EMI filter is required for European EMC directive and C-Tick, but the others are not for this purpose.

# DIMENSIONS

● **L300P-015-055LFU2**  
**015-055HFU2**  
**015-055HFE2**

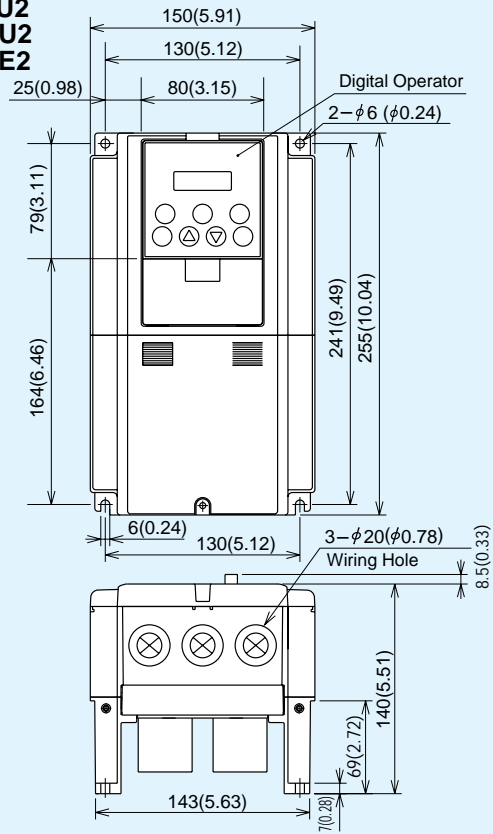

[Unit:mm (inch)]  
 Inches for reference only

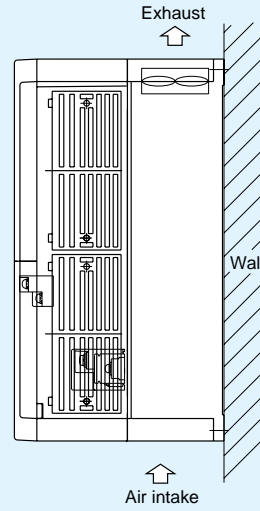

● **L300P-075-150LFU2, 075-150HFE2, 075-150HFU2**

[Unit:mm (inch)]  
 Inches for reference only

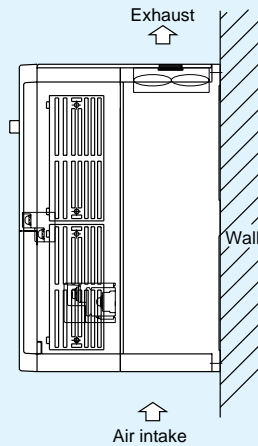
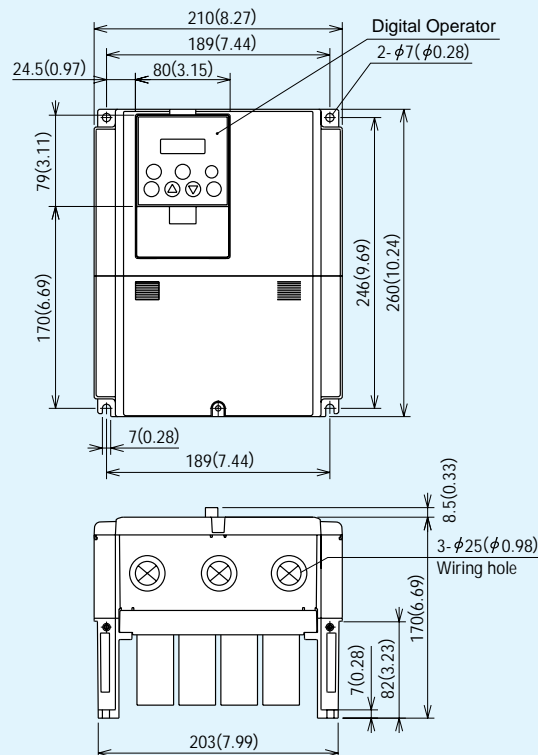

# DIMENSIONS

● **L300P-185-300LFU2,  
185-300HFE2,  
185-300HFU2**

[Unit:mm (inch)]  
Inches for reference only

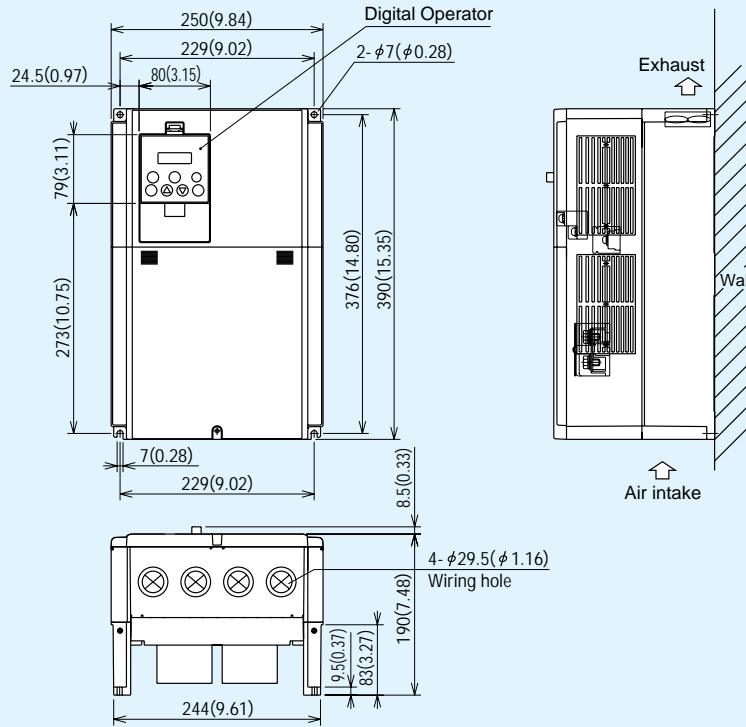

● **L300P-370LFU2,  
370HFE2,  
370HFU2**

[Unit:mm (inch)]  
Inches for reference only

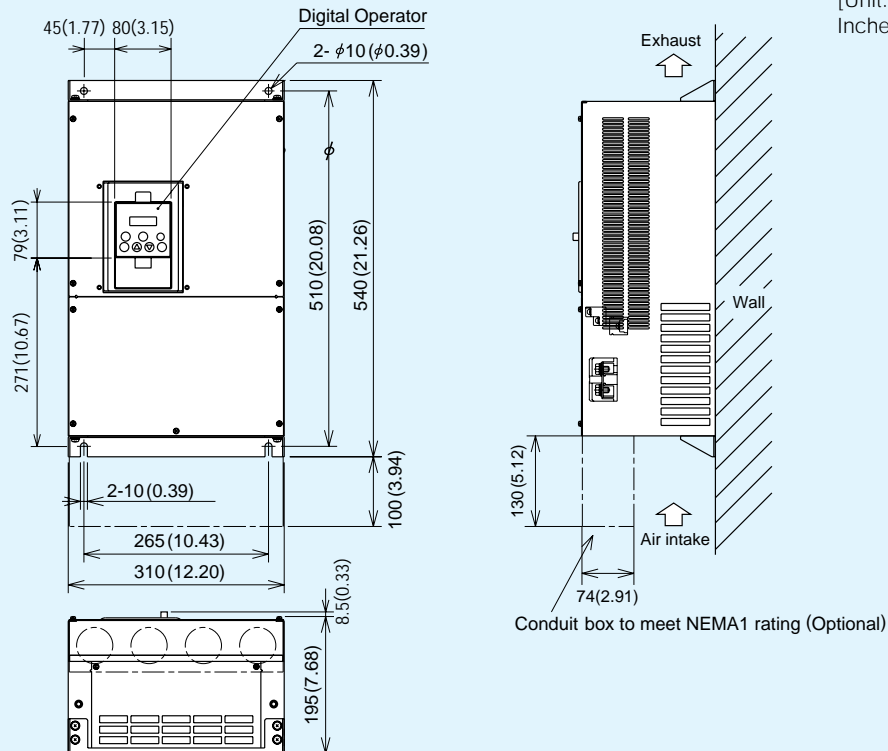

# CONNECTING TO PLC

## 1. USING INTERNAL POWER SUPPLY OF THE INVERTER

### (1) Sink type logic

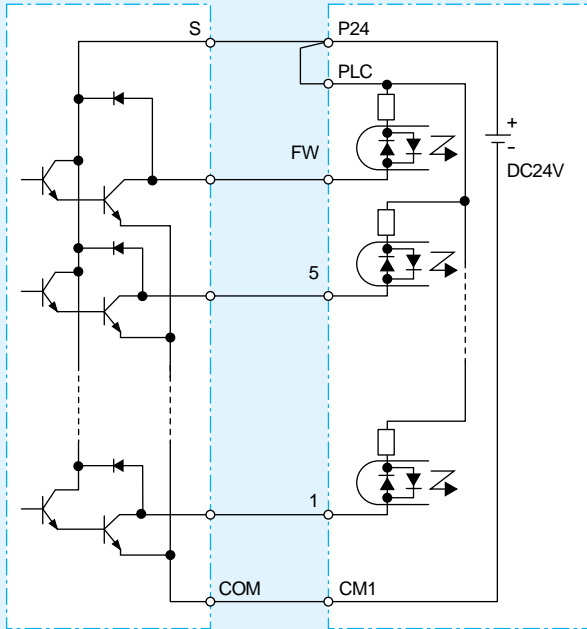

Hitachi EH-150 series PLC  
Output Module  
EH-YT16

L300P

### (2) Source type logic

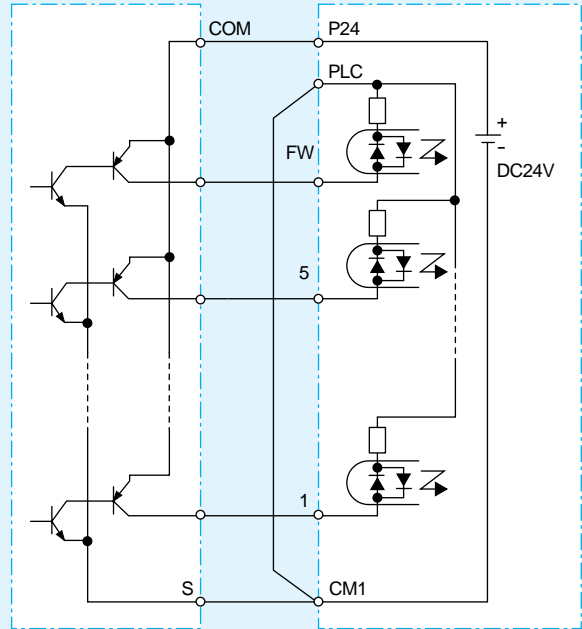

Hitachi EH-150 series PLC  
Output Module  
EH-YTP16

L300P

(Note: Place short-circuit bar between PLC and CM1 instead of P24 and PLC.)

## 2. USING EXTERNAL POWER SUPPLY

### (1) Sink type logic

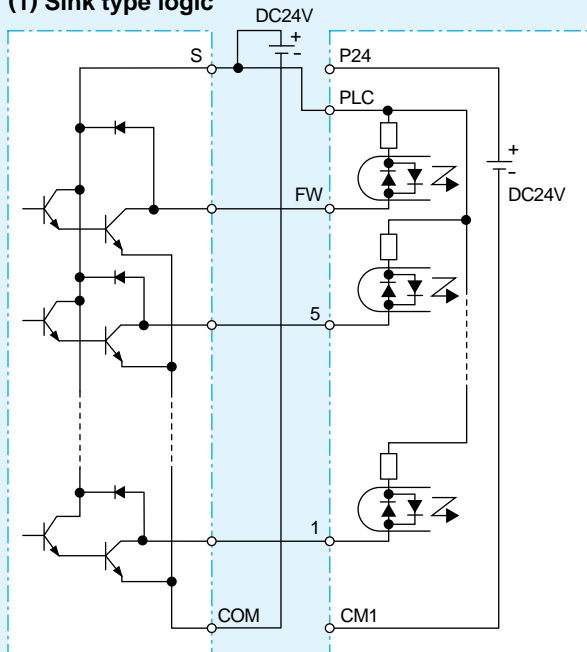

Hitachi EH-150 series PLC  
Output Module  
EH-YT16

L300P

(Note: Remove short-circuit bar between P24 and PLC.)

### (2) Source type logic

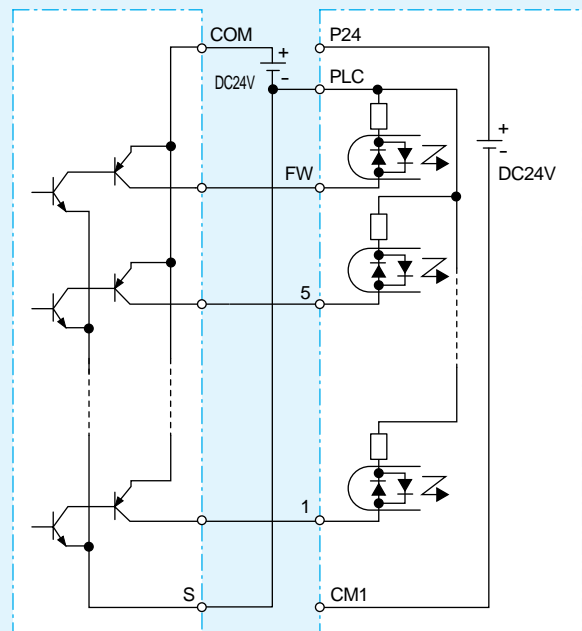

Hitachi EH-150 series PLC  
Output Module  
EH-YTP16

L300P

(Note: Remove short-circuit bar between P24 and PLC.)

(Note: Be sure to turn on the inverter after turning on the PLC and its external power supply to prevent the parameters in the inverter from being modified.)

# SINK TYPE LOGIC

In case of 400V class,  
place a transformer for operating circuit  
to receive 200V.

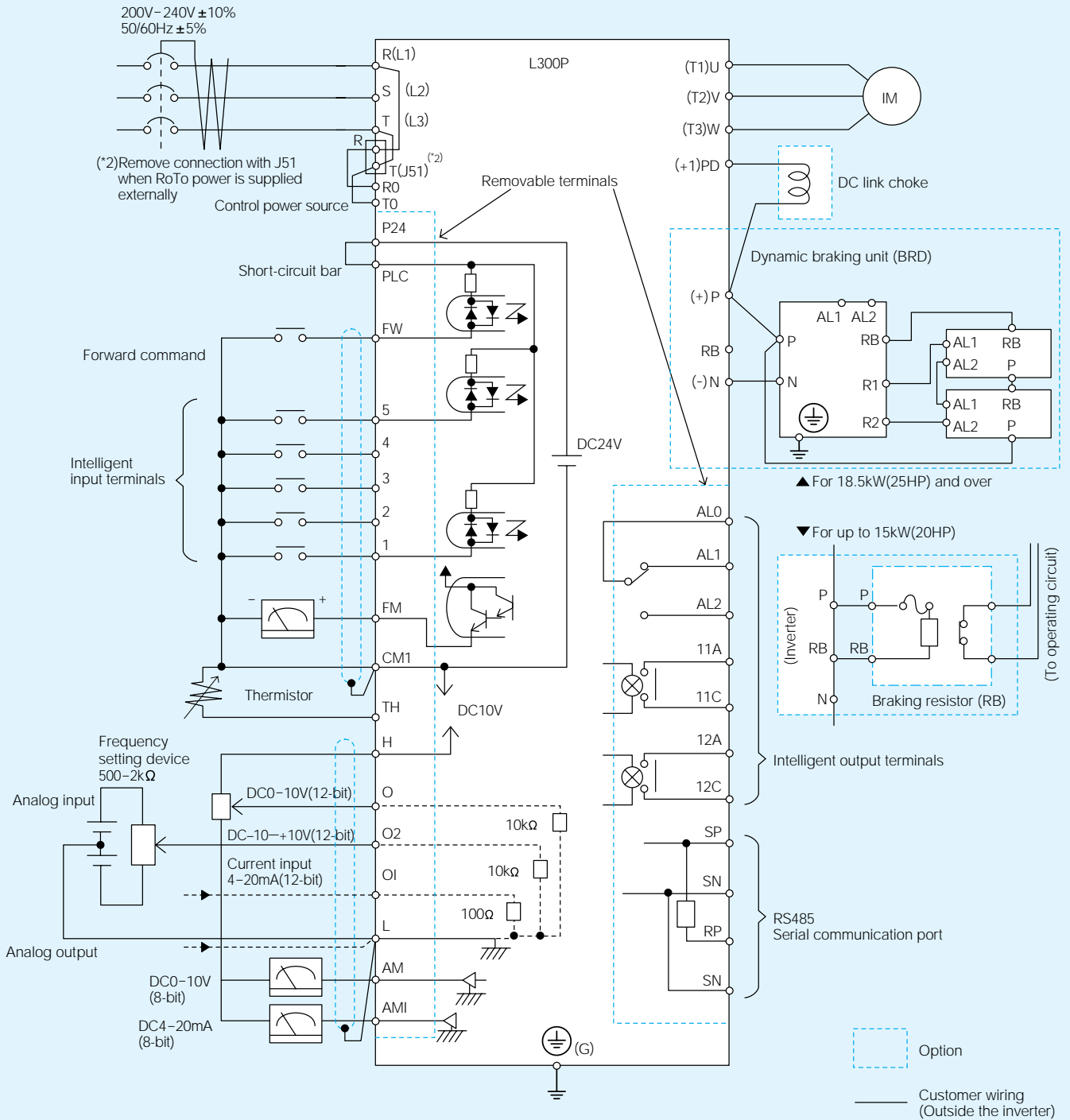

Terminal Name	FW, 1, 2, 3, 4, 5, FM, TH	H, O, O2, OI, AM, AMI
Common	CM1	L

● **L300P-450-550LFU2,  
450-750HFE2,  
450-750HFU2**

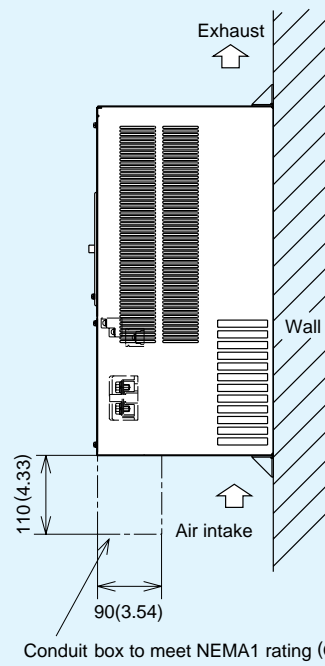
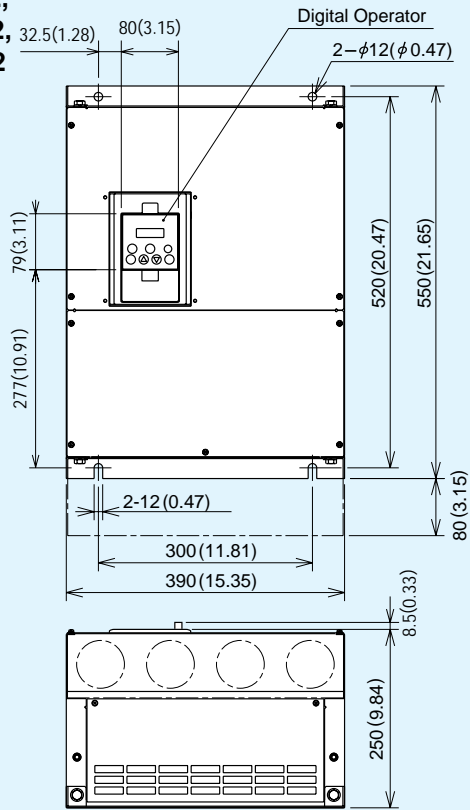

[Unit:mm (inch)]  
Inches for reference only

● **L300P-750LFU2**

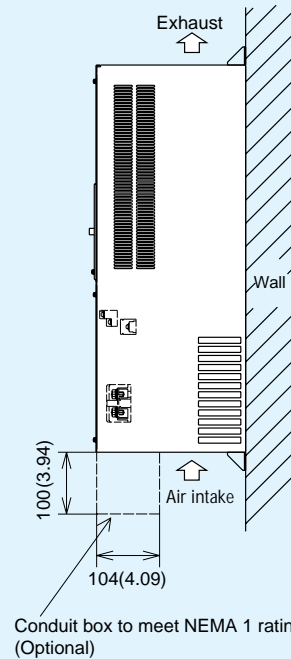
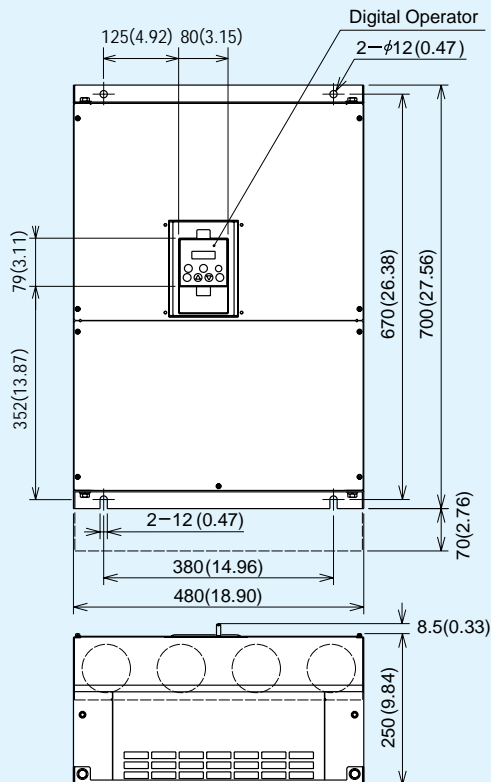

[Unit:mm (inch)]  
Inches for reference only

# DIMENSIONS

## ● L300P-900HFE2, HFU2 -1100HFE2, HFU2

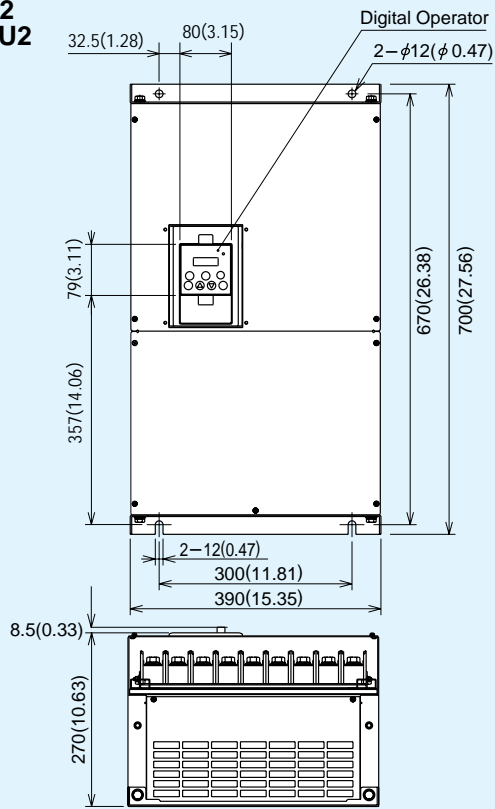

[Unit:mm (inch)]  
Inches for reference only

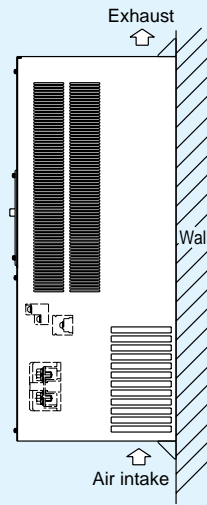

## ● L300P-1320HFE2, HFU2

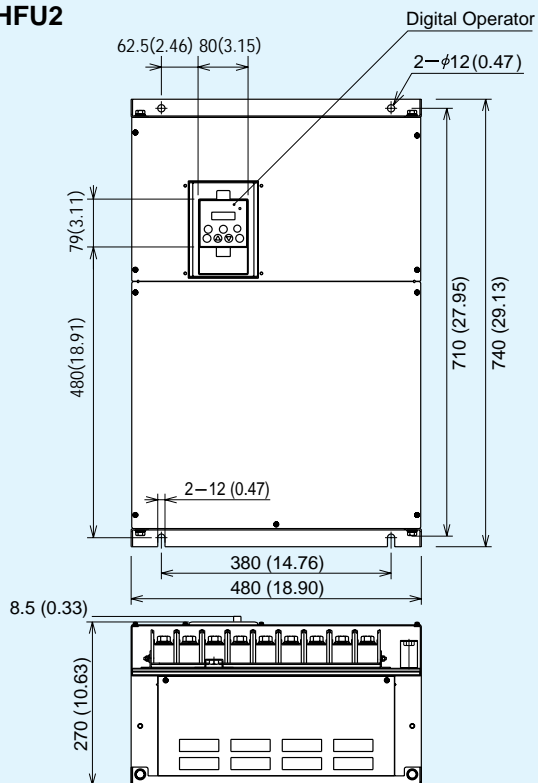

[Unit:mm (inch)]  
Inches for reference only

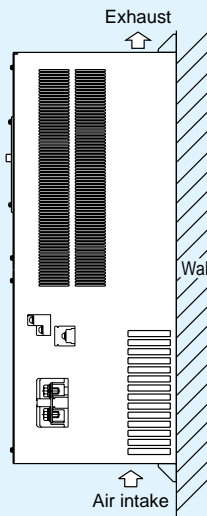

# CONNECTING DIAGRAM

## SOURCE TYPE LOGIC

In case of 400V class,  
place a transformer for operating circuit  
to receive 200V.

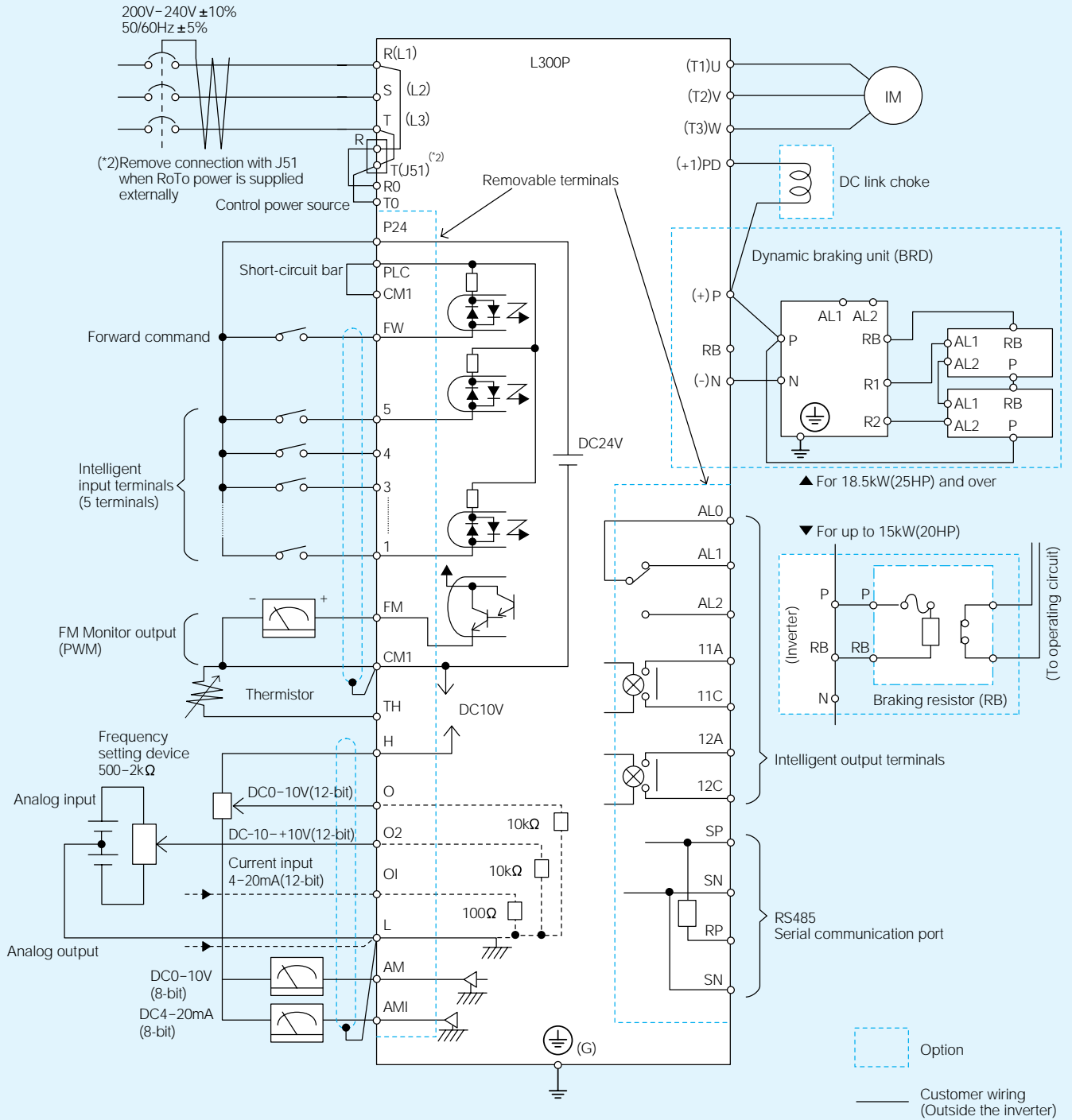

# PROTECTIVE FUNCTIONS

Name	Cause(s)	Display on digital operator	Display on remote operator/copy unit ERR1****	
Over-current protection	The inverter output was short-circuited, or the motor shaft is locked or has a heavy load. These conditions cause excessive current for the inverter, so the inverter output is turned off.	While at constant speed	<b>E01</b>	OC.Drive
		During deceleration	<b>E02</b>	OC.Drive
		During acceleration	<b>E03</b>	OC.Accel
		Others	<b>E04</b>	Over.C
Overload protection(*1)	When a motor overload is detected by the electronic thermal function, the inverter trips and turns off its output.	<b>E05</b>	Over.L	
Braking resistor overload protection	When the regenerative braking resistor exceeds the usage time allowance or an over-voltage caused by the stop of the BRD function is detected, the inverter trips and turns off its output.	<b>E06</b>	OL.BRD	
Over-voltage protection	When the DC bus voltage exceeds a threshold, due to regenerative energy from the motor, the inverter trips and turns off its output.	<b>E07</b>	Over.V	
EEPROM error(*2)	When the built-in EEPROM memory has problems due to noise or excessive temperature, the inverter trips and turns off its output.	<b>E08</b>	EEPROM	
Under-voltage error	A decrease of internal DC bus voltage below a threshold results in a control circuit fault. This condition can also generate excessive motor heat or cause low torque. The inverter trips and turns off its output.	<b>E09</b>	Under.V	
CT(Current transformer) error	If a strong source of electrical interference is close to the inverter or abnormal operations occur in the built-in CT(Current transformer), the inverter trips and turns off its output.	<b>E10</b>	CT	
CPU error	When a malfunction in the built-in CPU has occurred, the inverter trips and turns off its output.	<b>E11</b>	CPU1	
External trip	When a signal to an intelligent input terminal configured as EXT has occurred, the inverter trips and turns off its output.	<b>E12</b>	EXTERNAL	
USP error	An error occurs when power is cycled while the inverter is in RUN mode if the Unattended Start Protection (USP) is enabled. The inverter trips and does not go into RUN mode until the error is cleared.	<b>E13</b>	USP	
Ground fault	The inverter is protected by the detection of ground faults between the inverter output and the motor during power-up tests. This feature protects the inverter only.	<b>E14</b>	GND.Fit.	
Input over-voltage protection	When the input voltage is higher than the specified value, it is detected 60 seconds after power-up and the inverter trips and turns of its output.	<b>E15</b>	OV.SRC	
Instantaneous power failure	When power is cut for more than 15msec., the inverter trips and turns off its output. If power failure continues, the error will be cleared. The inverter restarts if it is in RUN mode when power is cycled.	<b>E16</b>	Inst.P-F	
Inverter thermal trip	When the inverter internal temperature is higher than the specified value, the thermal sensor in the inverter module detects the higher temperature of the power devices and trips, turning off the inverter output.	<b>E21</b>	OH.FIN	
Gate array error	Communication error has occurred between CPU and gate array.	<b>E23</b>	GA	
Missing phase	One of three lines of 3-phase power supply is missing.	<b>E24</b>	PH.Fail	
IGBT error	When instantaneous over-current has occurred, the inverter trips and turns off its output to protect main circuit element.	<b>E30</b>	IGBT	
Thermistor error	When the thermistor inside the motor detects temperature higher than the specified value, the inverter trips and turns off its output.	<b>E35</b>	TH	
Expansion card 1 connection error	An error has been detected in an expansion card or at its connecting terminals.	<b>E60-E69</b>	OP1 0-9	
Expansion card 2 connection error		<b>E70-E79</b>	OP2 0-9	
Out of operation due to under-voltage	Due to insufficient voltage, the inverter has turned off its output and been trying to restart. If it fails to restart, it goes into the under-voltage error.	<b>--U</b>	UV.WAIT	

(\*1)You can clear the error by pressing the Start / Reset key 10 seconds after the trip occurred.

(\*2)If an EEPROM error **E08** occurs, be sure to confirm the parameter data values are still correct.

## <How to access the details about the present fault>

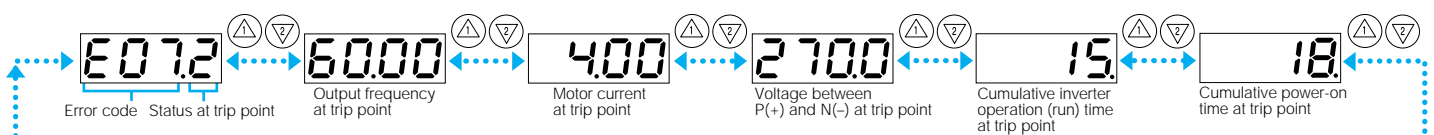

# OPERATION and PROGRAMMING

L300P Series can be easily operated with the digital operator (OPE-SR) provided as standard. The Digital operator can also be detached and used for remote-control. A multilingual (English, French, German Italian, Spanish, and Portuguese) operator with copy function (SRW-0EX) or a digital operator without potentiometer(OPE-S) is also available as an option. (For US version, OPE-SRE (English overlay with potentiometer) is provided as standard.)

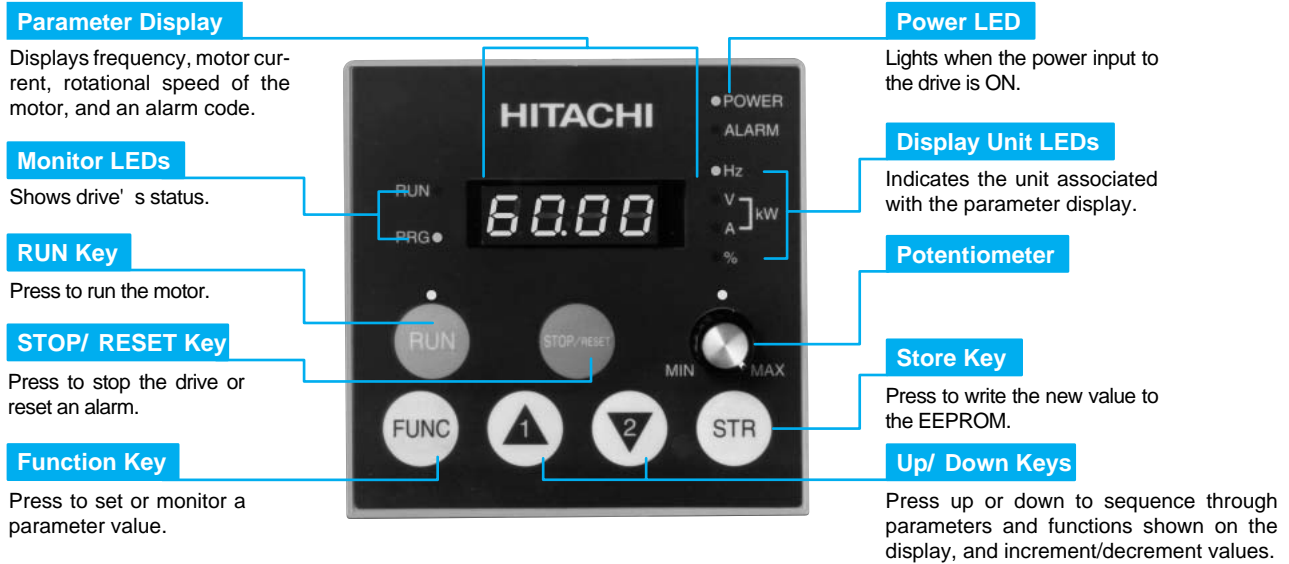

## 1. Setting the maximum output frequency

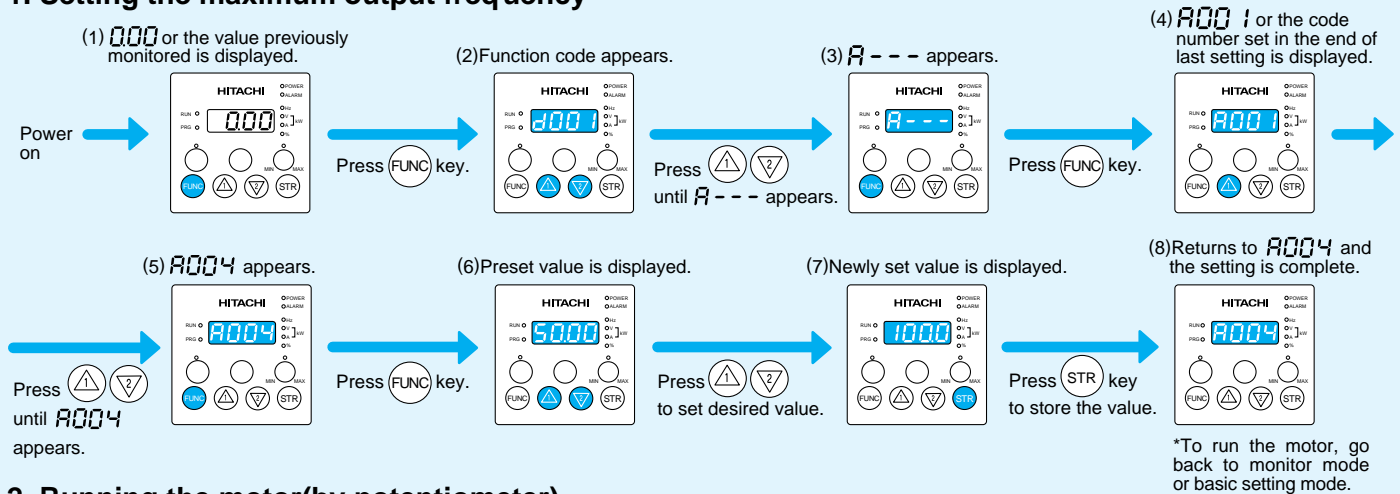

## 2. Running the motor (by potentiometer)

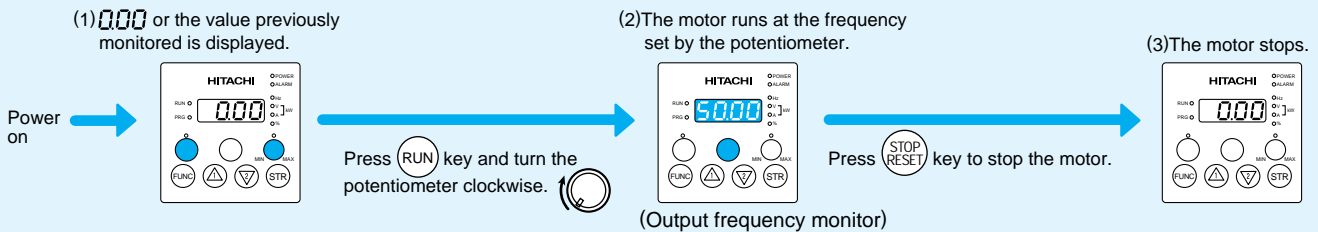

## 3. Monitoring output current value

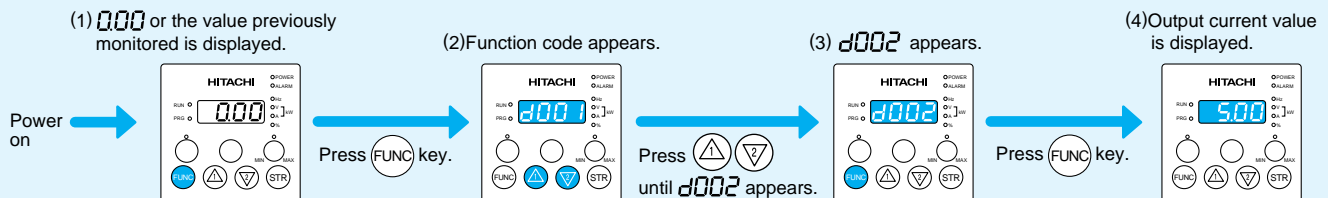

# FUNCTION LIST

## ● Monitoring Functions and Main Profile Parameters

[ O = Allowed  
X = Not permitted ]

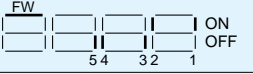
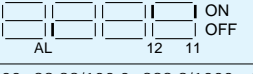
Code	Name	Description	Default Setting		Run-time Setting	Run-time Data Edit (Enabled at b031)	
			-FE(CE)	-FU2(UL)			
d001	Output frequency monitor	0.00-99.99/100.0-400.0Hz	-	-	-	-	
d002	Output current monitor	0.0-999.9A	-	-	-	-	
d003	Motor rotational direction monitor	F(Forward) / o(Stop) / r(Reverse)	-	-	-	-	
d004	Process variable (PV), PID feedback monitor	0.00-99.99/100.0-999.9/1000.-9999./1000-9999/[100- [999(10,000-99,900)	-	-	-	-	
Monitor Mode	d005	Intelligent input terminal status 	-	-	-	-	
	d006	Intelligent output terminal status 	-	-	-	-	
	d007	Scaled output frequency monitor	0.00-99.99/100.0-999.9/1000.-9999./1000-3996(10,000-39,960)	-	-	-	-
	d013	Output voltage monitor	0.0-600.0V	-	-	-	-
	d014	Power monitor	0.0-999.9kW	-	-	-	-
	d016	Cumulative RUN time monitor	0.-9999./1000-9999/[100- [999 (10,000-99,900)hr	-	-	-	-
	d017	Cumulative power-on time monitor	0.-9999./1000-9999/[100- [999 (10,000-99,900)hr	-	-	-	-
	d080	Trip count monitor	0.-9999./1000-6553(10,000-65,530)	-	-	-	-
	d081 d086	Trip monitor 1-6	Displays trip event information	-	-	-	-
	d090	Warning monitor	Warning code	-	-	-	-
Setting Mode	F001	Output frequency setting	0.0, Starting frequency to maximum frequency / maximum frequency for second motor	0.00Hz	0.00Hz	O	O
	F002	Acceleration time (1) setting	0.01-99.99/100.0-999.9/1000.-3600. sec.	30.00s	60.00s	O	O
	F202	Acceleration time (1) setting for second motor	0.01-99.99/100.0-999.9/1000.-3600. sec.	30.00s	60.00s	O	O
	F003	Deceleration time (1) setting	0.01-99.99/100.0-999.9/1000.-3600. sec.	30.00s	60.00s	O	O
	F203	Deceleration time (1) setting for second motor	0.01-99.99/100.0-999.9/1000.-3600. sec.	30.00s	60.00s	O	O
	F004	Motor rotational direction setting	00(Forward) / 01 (Reverse)	00	00	X	X
Expanded Function	A---	A Group: Standard functions					
	b---	b Group: Fine tuning functions					
	C---	C Group: Intelligent terminal functions					
	H---	H Group: Motor constants functions					
	P---	P Group: Expansion card functions					
	U---	U Group: User-selectable menu functions					

## ● A Group: Standard Functions

[ O = Allowed  
X = Not permitted ]

Code	Name	Description	Default Setting		Run-time Setting	Run-time Data Edit (Enabled at b031)	
			-FE(CE)	-FU2(UL)			
Basic Setting	A001	Frequency source setting	00(Potentiometer) / 01(Terminals) / 02(Operator) / 03(RS485) / 04 (Expansion card 1) / 05(Expansion card 2)	01	01	X	X
	A002	Run command source setting	01(Terminals) / 02(Operator) / 03(RS485) / 04 (Expansion card 1) / 05(Expansion card 2)	01	01	X	X
	A003	Base frequency setting	30.00Hz-Maximum frequency	50.	60.	X	X
	A203	Base frequency setting for second motor	30.00Hz-Maximum frequency for second motor	50.	60.	X	X
	A004	Maximum frequency setting	30.00-400.0Hz	50.	60.	X	X
Analog Input Setting	A204	Maximum frequency setting for second setting	30.00-400.0Hz	50.	60.	X	X
	A005	AT selection	00(Selection between O and OI at AT) / 01(Selection between O and O2 at AT)	00	00	X	X
	A006	O2 selection	00(Independent) / 01(Only positive) / 02(Both positive and negative)	00	00	X	X
	A011	O-L input active range start frequency	0.00-400.0Hz	0.00	0.00	X	O
	A012	O-L input active range end frequency	0.00-400.0Hz	0.00	60.00	X	O
	A013	O-L input active range start voltage	0.-100.%	0.	0.	X	O
	A014	O-L input active range end voltage	0.-100.%	100.	100.	X	O
	A015	O-L input start frequency enable	00(External frequency output zero reference) / 01(0Hz)	01	01	X	O
	A016	External frequency filter time constant	1.-30. (Sampling time = 2 msec.)	8.	8.	X	O
	A019	Multispeed operation selection	00(Binary: up to 16-stage speed at 4 terminals) / 01(Bit: up to 6-stage speed at 5 terminals)	00	00	X	X
Multispeed and Jogging Frequency Setting	A020	Multispeed frequency setting (0)	0.00, Starting frequency to maximum frequency	0.00	0.00	O	O
	A220	Multispeed frequency setting (0) for second motor	0.00, Starting frequency to maximum frequency for second motor	0.00	0.00	O	O
	A021 A035	Multispeed frequency setting (1-15)	0.00, Starting frequency to maximum frequency	0.00	0.00	O	O
	A038	Jog frequency setting	0.00, Starting frequency to 9.99Hz	1.00	1.00	O	O
A039	Jog stop mode	00(Free-run stop/disable during RUN) / 01(Deceleration to stop/ disable during RUN) / 02(DC braking to stop/ disable during RUN) / 03(Free-run stop/ enable during RUN) / 04(Deceleration to stop/ enable during RUN) / 05(DC braking to stop/ enable during RUN)	00	00	X	O	

## Control Circuit Terminals

### Terminal Description [ ]: Default setting (CE/ UL)

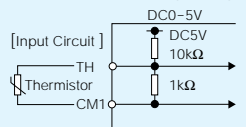
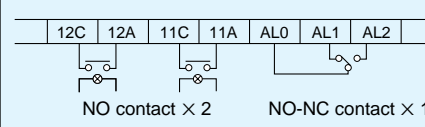
		Symbol	Name	Explanation of Terminals	Ratings	
Analog	Power Supply		L	Common Terminal for Analog Power Source	Common terminal for H, O, O2, OI, AM, and AMI. Do not ground.	—
			H	Power Source for Frequency Setting	Power supply for frequency command input	DC 10V, 20mA max.
	Frequency Setting		O	Frequency Command Terminal	Maximum frequency is attained at DC 10V in DC 0–10V range. Set the voltage at A014 to command maximum frequency below DC 10V.	Input impedance: 10kΩ, Allowable input voltage range: DC –0.3–+12V
			O2	Frequency Command Extra Terminal	O2 signal is added to the frequency command of O or OI in DC 0–±10V range. By changing configuration, frequency command can be input also at O2 terminal.	Input impedance: 10kΩ, Allowable input voltage range: DC 0–±12V
			OI	Frequency Command Terminal	Maximum frequency is attained at DC 20mA in DC 4–20mA range. When the intelligent terminal configured as AT is on, OI signal is enabled.	Input impedance: 100Ω, Allowable input voltage range: DC 0–24mA
	Monitor Output		AM	Analog Output Monitor (Voltage)	Selection of one function from: Output frequency, output current, torque, output voltage, input power, electronic thermal load ratio, and LAD frequency.	DC 0–10V, 2mA max.
			AMI	Analog Output Monitor (Current)		DC 4–20mA, 250Ω max.
	Analog Input	Sensor	TH	Thermistor Input Terminals	The inverter trips when the external thermistor detects abnormal temperature. Common terminal is CM1. [Recommended thermistor characteristics] Allowable rated power: 100mW or over. Impedance in the case of abnormal temperature: 3kΩ Note: Thermal protection level can be set between 0 and 9999Ω.	Allowable input voltage range 
	Monitor Output		FM	Digital Monitor (Voltage)	[DC0-10V output (PWM output)] Selection of one function from: Output frequency, output current, torque, output voltage, input power, electronic thermal load ratio, and LAD frequency. [Digital pulse output (Pulse voltage DC 0/10V)] Outputs the value of output frequency as digital pulse (duty 50%)	Digital output frequency range: 0–3.6kHz, 1.2mA max.
	Power Supply		P24	Power Terminal for Interface	Internal power supply for input terminals. In the case of source type logic, common terminal for contact input terminals.	DC 24V, 100mA max.
CM1			Common Terminal for Interface	Common terminal for P24, TH, and FM. In the case of sink type logic, common terminal for contact input terminals. Do not ground.	—	
Digital	Contact Input	Run Command	FW	Forward Command Input	The motor runs forward when FW terminal is ON, and stops when FW is OFF.	[Input ON condition] Voltage between each terminal and PLC: DC 18V min.
		Functions	1 [RS/RS]	Intelligent Input Terminals	Assign 5 functions to terminals. (Refer to the standard specifications for the functions.)	[Input OFF condition] Voltage between each terminal and PLC: DC 3V max.
			2 [AT/AT]			
			3 [CF2/USP]			
4 [CF1/CF1]						
5 [RV/RV]						
Common Terminal	PLC	Common Terminal for Intelligent Input Terminals, Common Terminal for External Power Supply for PLCs, etc.	Select sink or source logic with the short-circuit bar on the control terminals. Sink logic: Short P24 to PLC / Source logic: Short CM1 to PLC. When applying external power source, remove the short-circuit bar and connect PLC terminal to the external device.	Allowable maximum voltage between each terminal and PLC: DC 27V		
Relay Output	State/Alarm	12C [RUN/RUN] 12A [RUN/RUN] 11C [FA1/FA1] 11A [FA1/FA1] AL0 [AL/AL] AL1 [AL/AL] AL2 [AL/AL]	Intelligent Output Terminals	Assign 3 functions to two NO contacts and one NO-NC contact. (Refer to the standard specifications for the functions.)  <b>Intelligent relay output terminals</b>  NO contact × 2      NO-NC contact × 1	Maximum capacity of relays 11,12: AC 250V, 5A(R load)/1A(I load) DC 30V, 5A(R load)/1A(I load) AL1–AL0: AC 250V, 2A(R load)/0.2A(I load) DC 30V, 8A(R load)/0.6A(I load) AL2–AL0: AC 250V, 1A(R load)/0.2A(I load) DC 30V, 1A(R load)/0.2A(I load) Minimum capacity of relays 11,12: DC 1V, 1mA AL1–AL0, AL2–AL0: AC100V, 10mA DC5V, 100mA	

## Main Circuit Terminals

### Terminal Description

Terminal Symbol	Terminal Name
R(L1), S(L2), T(L3)	Main power supply input terminals
U(T1), V(T2), W(T3)	Inverter output terminals
PD(+1), P(+)	DC reactor connection terminals
P(+), RB(RB)	External braking resistor connection terminals
P(+), N(-)	External braking unit connection terminals
⊕(G)	Ground connection terminal
R0(R0), T0(T0)	Control power supply input terminals

### Terminal Arrangement

■ 015-055 LFU2, HFU2, HFE2

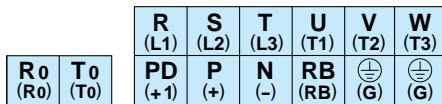

■ 110-150HFE2, 075-150HFU2/LFU2

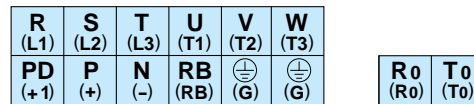

■ 185-370LFU2  
185-750HFE2, HFU2

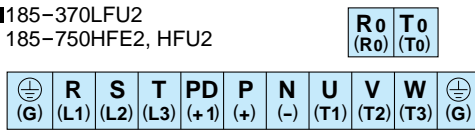

■ 220, 300, 450, 550, 750LFU2  
900-1320HFE2/HFU2

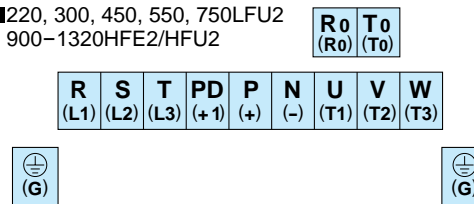

### Screw Diameter and Terminal Width

Model	Main Circuit Terminals									R0, T0 Terminals
	015-037 LFU2 HFE2/HFU2	055LFU2 HFE2/HFU2	075LFU2 HFE2/HFU2	110-150LFU2 HFE2/HFU2	185LFU2,185-370 HFE2/HFU2	220-370LFU2, 450-750HFE2/HFU2	450-550 LFU2	750LFU2, 1320HFE2/HFU2	900-1100 HFE2/HFU2	All models
Screw diameter	M4	M5	M5	M6	M6	M8	M10	M10	M10	M4
Terminal width (mm)	13	13	17.5	17.5	18	23	35	40	29	9

\*For ground screw of 200, 300, 450, 550 LFU2, M6 is used. For 900-1320HFE/HFU2, M8 is used.

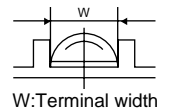

## Control Circuit Terminals

### Terminal Arrangement

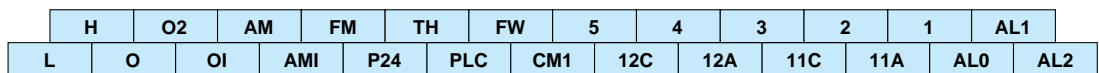

Screw diameter M3, Terminal width 6.4mm

○ = Allowed  
 ✕ = Not permitted

Code	Name	Description	Default Setting		Run-time Setting	Run-time Data Edit (Enabled at 0031)		
			-FE(CE)	-FU2(UL)				
V/f Characteristic	A041	Torque boost method selection	00(Manual torque boost) / 01(Automatic torque boost)		✕	✕		
	A241	Torque boost method selection for second motor	00(Manual torque boost) / 01(Automatic torque boost)		✕	✕		
	A042	Manual torque boost value	0.0-20.0%		○	○		
	A242	Manual torque boost value for second motor	0.0-20.0%		○	○		
	A043	Manual torque boost frequency adjustment	0.0-50.0%		○	○		
	A243	Manual torque boost frequency adjustment for second motor	0.0-50.0%		○	○		
	A044	V/f characteristic curve selection	00(VC) / 01(VP 1.7th power) / 02(V/f free-setting)		✕	✕		
	A244	V/f characteristic curve selection for second motor	00(VC) / 01(VP 1.7th power) / 02(V/f free-setting)		✕	✕		
A045	V/f gain setting	20.-100.		○	○			
DC Braking	A051	DC braking enable	00(Disabled) / 01(Enabled)		✕	○		
	A052	DC braking frequency setting	0.00-60.00Hz		✕	○		
	A053	DC braking wait time	0.0-5.0sec.		✕	○		
	A054	DC braking force setting	0.-70.%		✕	○		
	A055	DC braking time setting	0.0-60.0sec.		✕	○		
	A056	DC braking edge or level detection	00(Edge) / 01(Level)		✕	○		
	A057	DC braking force setting at the starting point	0.-70.%		✕	○		
	A058	DC braking time setting at the starting point	0.0-60.0sec.		✕	○		
A059	DC braking carrier frequency setting	0.5-12kHz (To be derated) {0.5-8kHz} <sup>(*)</sup>		✕	✕			
Upper/Lower Limit and Jump Frequency	A061	Frequency upper limit setting	0.00, Starting frequency to maximum frequency		✕	○		
	A261	Frequency upper limit setting for second motor	0.00, Starting frequency to maximum frequency for second motor		✕	○		
	A062	Frequency lower limit setting	0.00, Starting frequency to maximum frequency		✕	○		
	A262	Frequency lower limit setting for second motor	0.00, Starting frequency to maximum frequency for second motor		✕	○		
	A063	Jump frequency (1) setting	0.00-99.99/100.0-400.0Hz		✕	○		
	A064	Jump frequency width (1) setting	0.00-10.00Hz		✕	○		
	A065	Jump frequency (2) setting	0.00-99.99/100.0-400.0Hz		✕	○		
	A066	Jump frequency width (2) setting	0.00-10.00Hz		✕	○		
	A067	Jump frequency (3) setting	0.00-99.99/100.0-400.0Hz		✕	○		
	A068	Jump frequency width (3) setting	0.00-10.00Hz		✕	○		
PID Control	A069	Acceleration hold frequency setting	0.00-99.99/100.0-400.0Hz		✕	○		
	A070	Acceleration stop time setting	0.0-60.0sec.		✕	○		
	A071	PID function enable	00(Disable) / 01(Enable)		✕	○		
	A072	PID proportional gain	0.2-5.0		○	○		
	A073	PID integral gain	0.0-3600.0sec.		○	○		
	A074	PID differential gain	0.0-100.0sec.		○	○		
	A075	Process variable scale conversion	0.01-99.99%		✕	○		
AVR Function	A076	Process variable source setting	00(at OI) / 01(at O)		✕	○		
	A081	AVR function selection	00(Always ON) / 01(Always OFF) / 02(OFF during deceleration)		✕	✕		
Operation Mode and Accel./Decel. Function	A082	AVR voltage selection	200/215/220/230/240, 380/400/415/440/460/480V		230/400	230/460	✕	✕
	A085	Operation mode selection	00(Normal operation) / 01(Energy-saving operation)		✕	✕	✕	✕
	A086	Energy saving mode tuning	0.0-100.0sec.		○	○	○	○
	A092	Acceleration time (2)	0.01-99.99/100.0-999.9/1000.-3600.sec.		○	○	○	○
	A292	Acceleration time (2) for second motor	0.01-99.99/100.0-999.9/1000.-3600.sec.		○	○	○	○
	A093	Deceleration time (2)	0.01-99.99/100.0-999.9/1000.-3600.sec.		○	○	○	○
	A293	Deceleration time (2) for second motor	0.01-99.99/100.0-999.9/1000.-3600.sec.		○	○	○	○
	A094	Select method to switch to second accel./ decel. profile	00(2CH input from terminal) / 01(Transition frequency)		✕	✕	✕	✕
	A294	Select method to switch to second accel./ decel. profile for second motor	00(2CH input from terminal) / 01(Transition frequency)		✕	✕	✕	✕
	A095	Accel(1) to Accel(2) frequency transition point	0.00-99.99/100.0-400.0Hz		✕	✕	✕	✕
	A295	Accel(1) to Accel(2) frequency transition point for second motor	0.00-99.99/100.0-400.0Hz		✕	✕	✕	✕
	A096	Decel(1) to Decel(2) frequency transition point	0.00-99.99/100.0-400.0Hz		✕	✕	✕	✕
	A296	Decel(1) to Decel(2) frequency transition point for second motor	0.00-99.99/100.0-400.0Hz		✕	✕	✕	✕
	A097	Acceleration curve selection	00(Linear) / 01(S-curve) / 02(U-shape) / 03(Reverse U-shape)		✕	✕	✕	✕
A098	Deceleration curve selection	00(Linear) / 01(S-curve) / 02(U-shape) / 03(Reverse U-shape)		✕	✕	✕	✕	
External Frequency Tuning	A101	OI-L input active range start frequency	0.00-400.0Hz		✕	○	○	○
	A102	OI-L input active range end frequency	0.00-400.0Hz		✕	○	○	○
	A103	OI-L input active range start voltage	0.-100.%		✕	○	○	○
	A104	OI-L input active range end voltage	0.-100.%		✕	○	○	○
	A105	OI-L input start frequency enable	00(External frequency output zero reference) / 01(0Hz)		✕	○	○	○
	A111	O2-L input active range start frequency	-400.0-400.0Hz		✕	○	○	○
	A112	O2-L input active range end frequency	-400.0-400.0Hz		✕	○	○	○
	A113	O2-L input active range start voltage	-100.-100.%		✕	○	○	○
Accel./Decel. Curve	A114	O2-L input active range end voltage	-100.-100.%		✕	○	○	○
	A131	Acceleration curve constants setting	01(Smallest deviation)-10(Largest deviation)		✕	○	○	○
A132	Deceleration curve constants setting	01(Smallest deviation)-10(Largest deviation)		✕	○	○	○	

(\*) 90kW and over

## ●B Group : Fine Tuning Functions

○ = Allowed  
 × = Not permitted

Code	Name	Description	Default Setting		Run-time Setting	Run-time Data Edit (Enabled at b031)		
			-FE(CE)	-FU2(UL)				
Restart after Instantaneous Power Failure	b001	Selection of automatic restart mode	00(Alarm output after trip, automatic restart disable) / 01(Restart at 0Hz) / 02(Resume operation after frequency matching) / 03(Resume previous frequency after frequency matching, then decelerate to stop and display trip information)		00	00	×	○
	b002	Allowable instantaneous power failure time	0.3-25.0sec.		1.0	1.0	×	○
	b003	Time delay enforced before motor restart	0.3-100.0sec.		1.0	1.0	×	○
	b004	Instantaneous power failure and under-voltage trip enable	00(Disable) / 01(Enable) / 02(Disable during stop and ramp to stop)		00	00	×	○
	b005	Number of restarts after instantaneous power failure and under-voltage trip	00(16 times) / 01(Always restart)		00	00	×	○
	b006	Phase loss detection enable	00(Disable) / 01(Enable)		01	01	×	○
	b007	Restart frequency setting	0.00-99.99/100.0-400.0Hz		0.00	0.00	×	○
Electronic Thermal	b012	Level of electronic thermal setting	0.20*rated current-1.20*rated current		Rated current	Rated current	×	○
	b212	Level of electronic thermal setting for second motor	0.20*rated current-1.20*rated current		Rated current	Rated current	×	○
	b013	Electronic thermal characteristics	00(Reduced torque) / 01(Constant torque) / 02(V/f free-setting)		01	00	×	○
	b213	Electronic thermal characteristics for second motor	00(Reduced torque) / 01(Constant torque) / 02(V/f free-setting)		01	00	×	○
	b015	Free-setting electronic thermal frequency (1)	0-400.Hz		0.	0.	×	○
	b016	Free-setting electronic thermal current (1)	0.0-1000.A		0.0	0.0	×	○
	b017	Free-setting electronic thermal frequency (2)	0-400.Hz		0.	0.	×	○
	b018	Free-setting electronic thermal current (2)	0.0-1000.A		0.0	0.0	×	○
	b019	Free-setting electronic thermal frequency (3)	0-400.Hz		0.	0.	×	○
b020	Free-setting electronic thermal current (3)	0.0-1000.A		0.0	0.0	×	○	
Overload Restriction	b021	Overload restriction operation mode	00(Disable) / 01(Enable during accel./constant speed) / 02(Enable during constant speed)		01	01	×	○
	b022	Overload restriction setting	0.50*rated current-1.50*rated current		Rated current* 1.20	Rated current* 1.10	×	○
	b023	Deceleration rate at overload restriction	0.10-30.00		1.00	15.00	×	○
	b024	Overload restriction operation mode (2)	00(Disable) / 01(Enable during accel./ constant speed) / 02(Enable at constant speed)		01	01	×	○
	b025	Overload restriction setting (2)	0.50*rated current-1.50*rated current		Rated current* 1.20	Rated current* 1.20	×	○
	b026	Deceleration rate at overload restriction (2)	0.10-30.00		1.00	1.00	×	○
Software Lock	b031	Software lock mode selection	00(All parameters except b031 are locked when SFT from terminal is on) / 01(All parameters except b031 and output frequency F001 are locked when SFT from terminal is on) / 02(All parameters except b031 are locked) / 03(All parameters except b031 and output frequency F001 are locked) / 10(Run-time data edit mode)		01	01	×	○
Others	b034	RUN/ power-on warning time	0-9999/1000-6553(10,000-65,5300)hr (Output to intelligent terminal)		0.	0.	×	○
	b035	Rotational direction restriction	00(Enable for both directions) / 01(Enable for forward) / 02(Enable for reverse)		00	00	×	×
	b036	Reduced voltage soft start selection	00(Short)-06(Long)		06	06	×	○
	b037	Function code display restriction	00(All) / 01(Utilized functions) / 02(User-selected functions only)		00	00	×	○
	b080	AM terminal analog meter adjustment	0-255		180	180	○	○
	b081	FM terminal analog meter adjustment	0-255		60	60	○	○
	b082	Start frequency adjustment	0.10-9.99Hz		0.50	0.50	×	○
	b083	Carrier frequency setting	0.5-12.0kHz (To be derated) {0.5-8kHz}(*1)		3.0	3.0	×	○
	b084	Initialization mode	00(Trip history clear) / 01(Parameter initialization) / 02(Trip history clear and parameter initialization)		00	00	×	×
	b085	Country code for initialization	00(Japanese version) / 01(European version) / 02(North American version)		01	02	×	×
	b086	Frequency scaling conversion factor	0.1-99.9		1.0	1.0	○	○
	b087	STOP key enable	00(Enable) / 01(Disable)		00	00	×	○
	b088	Resume on free-run stop cancellation mode	00(Restart at 0Hz) / 01(Resume operation after frequency matching)		00	00	×	○
	b090	Dynamic braking usage ratio	0.0-100.0%		0.0	0.0	×	○
	b091	Stop mode selection	00(Deceleration and stop) / 01(Free-run stop)		00	00	×	×
	b092	Cooling fan control	00(Fan is always ON) / 01(Fan is ON during RUN including 5min. after power-on and stop)		00	00	×	×
	b095	Dynamic braking control	00(Disable) / 01(Enable during run) / 02(Enable during stop)		00	00	×	○
	b096	Dynamic braking activation level	330-380/660-760V		360/720	360/720	×	○
	b098	Thermistor for thermal protection control	00(Disable) / 01(PTC enable) / 02(NTC enable)		00	00	×	○
	b099	Thermistor for thermal protection level setting	0.0-9999Ω		3000	3000	×	○
Free-setting V/f pattern	b100	Free-setting V/f frequency (1)	0.-Free-setting V/f frequency (2)		0.0	0.0	×	×
	b101	Free-setting V/f voltage (1)	0.0-800.0V		0.0	0.0	×	×
	b102	Free-setting V/f frequency (2)	0.-Free-setting V/f frequency (3)		0.0	0.0	×	×
	b103	Free-setting V/f voltage (2)	0.0-800.0V		0.0	0.0	×	×
	b104	Free-setting V/f frequency (3)	0.-Free-setting V/f frequency (4)		0.0	0.0	×	×
	b105	Free-setting V/f voltage (3)	0.0-800.0V		0.0	0.0	×	×
	b106	Free-setting V/f frequency (4)	0.-Free-setting V/f frequency (5)		0.0	0.0	×	×
	b107	Free-setting V/f voltage (4)	0.0-800.0V		0.0	0.0	×	×
	b108	Free-setting V/f frequency (5)	0.-Free-setting V/f frequency (6)		0.0	0.0	×	×
	b109	Free-setting V/f voltage (5)	0.0-800.0V		0.0	0.0	×	×
	b110	Free-setting V/f frequency (6)	0.-Free-setting V/f frequency (7)		0.0	0.0	×	×
	b111	Free-setting V/f voltage (6)	0.0-800.0V		0.0	0.0	×	×
	b112	Free-setting V/f frequency (7)	0.-400.Hz		0.0	0.0	×	×
b113	Free-setting V/f voltage (7)	0.0-800.0V		0.0	0.0	×	×	

(\*1) 90kW and over

### ● C Group: Intelligent Terminal Functions

[○ = Allowed  
× = Not permitted]

Code	Name	Description	Default Setting		Run-time Setting	Run-time Data Edit (Enabled at t031)	
			-FE(CE)	-FU2(UL)			
Intelligent Input Terminal Setting	C001	Terminal (1) function	01(RV:Reverse) / 02(CF1:Multispeed(1)) / 03(CF2:Multispeed(2)) / 04(CF3:Multispeed(3)) / 05(CF4:Multispeed(4)) / 06(JG:Jogging) / 07(DB:External DC braking) / 08(SET:Second motor constants setting) / 09(2CH:Second accel./decel.) / 11(FRS:Free-run stop) / 12(EXT:External trip) / 13(USP:Unattended start protection) / 14(CS:Change to/from commercial power supply) / 15(SFT:Software lock) / 16(AT:Analog input selection) / 18(RS:Reset) / 20(STA:3-wire start) / 21(STP:3-wire hold) / 22(F/R:3-wire fwd./rev.) / 23(PID:PID On/Off) / 24(PIDC:PID reset) / 27(UP:Remote-controlled accel.) / 28(DWN:Remote-controlled decel.) / 29(UDC:Remote-controlled data clearing) / 31(OPE:Operator control) / 32(SF1:Multispeed bit command(1)) / 33(SF2:Multispeed bit command(2)) / 34(SF3:Multispeed bit command(3)) / 35(SF4:Multispeed bit command(4)) / 36(SF5:Multispeed bit command(5)) / 37(SF6:Multispeed bit command(6)) / 38(SF7:Multispeed bit command(7)) / 39(OLR:Overload limit change) / 49(ROK: RUN permissive)(*) / 255(NO:Not selected)	18	18	×	○
	C002	Terminal (2) function		16	16	×	○
	C003	Terminal (3) function		03	13	×	○
	C004	Terminal (4) function		02	02	×	○
	C005	Terminal (5) function		01	01	×	○
Intelligent Input Terminal State Setting	C011	Terminal (1) active state	00(NO) / 01(NC)	00	00	×	○
	C012	Terminal (2) active state	00(NO) / 01(NC)	00	00	×	○
	C013	Terminal (3) active state	00(NO) / 01(NC)	00	01	×	○
	C014	Terminal (4) active state	00(NO) / 01(NC)	00	00	×	○
	C015	Terminal (5) active state	00(NO) / 01(NC)	00	00	×	○
C019	Terminal FW active state	00(NO) / 01(NC)	00	00	×	○	
Intelligent Output Terminal Setting	C021	Terminal (11) function	00(RUN:Run signal) / 01(FA1:Frequency arrival signal (at the set frequency)) / 02(FA2:Frequency arrival signal (at or above the set frequency)) / 03(OL:Overload advance notice signal) / 04(OD:Output deviation for PID control) / 05(AL:Alarm signal) / 06(FA3:Frequency arrival signal (only at the set frequency)) / 08(IP:Instantaneous power failure signal) / 09(UV:Under-voltage signal) / 11(RNT:RUN time over) / 12(ONT:Power-on time over) / 13(THM:Thermal alarm) / 27(RMD: Operator RUN command signal)(*)	01	01	×	○
	C022	Terminal (12) function		00	00	×	○
	C026	Alarm relay terminal function		05	05	×	○
	C027	FM signal selection	00(Output frequency) / 01(Output current) / 03(Digital output frequency-only at C027) / 04(Output voltage) / 05(Power) / 06(Thermal load ratio) / 07(LAD frequency)	00	00	×	○
	C028	AM signal selection		00	00	×	○
Intelligent Output Terminal State and Output Level Setting	C029	AMI signal selection		00	00	×	○
	C031	Terminal (11) active state	00(NO) / 01(NC)	00	00	×	○
	C032	Terminal (12) active state	00(NO) / 01(NC)	00	00	×	○
	C036	Alarm relay terminal active state	00(NO) / 01(NC)	01	01	×	○
	C040	Overload signal output mode	00(During accel./decel) / 01(At constant speed)	01	01	×	○
	C041	Overload level setting	0.00*rated current-2.00*rated current	Rated current	Rated current	×	○
	C042	Arrival frequency setting for acceleration	0.00-99.99/100.0-400.0Hz	0.0	0.0	×	○
	C043	Arrival frequency setting for deceleration	0.00-99.99/100.0-400.0Hz	0.0	0.0	×	○
	C044	PID deviation level setting	0.0-100.0%	3.0	3.0	×	○
	C061	Electronic thermal warning level setting	0.-100.0%	80	80	×	○
Serial Communication	C070	Data command method	02(Operator) / 03(RS485) / 04 (Expansion card 1) / 05(Expansion card 2)	02	02	×	×
	C071	Communication speed selection	03(2400bps) / 04(4800bps) / 05(9600bps) / 06(19200bps)	04	04	×	○
	C072	Node allocation	1.-32.	1.	1.	×	○
	C073	Communication data length selection	7(7-bit) / 8(8-bit)	7	7	×	○
	C074	Communication parity selection	00(No parity) / 01(Even) / 02(Odd)	00	00	×	○
	C075	Communication stop bit selection	1(1-bit) / 2(2-bit)	1	1	×	○
	C078	Communication wait time	0.-1000.msec.	0.0	0.0	×	○
	C081	O input span calibration	0.-9999/1000-6553(10,000-65,530)	Factory set	Factory set	○	○
Analog Meter Setting	C082	O1 input span calibration	0.-9999/1000-6553(10,000-65,530)	Factory set	Factory set	○	○
	C083	O2 input span calibration	0.-9999/1000-6553(10,000-65,530)	Factory set	Factory set	○	○
	C085	Thermistor input tuning	0.0-1000.	105	105	○	○
	C086	AM terminal offset tuning	0.0-10.0V	0.0	0.0	○	○
	C087	AMI terminal meter tuning	0.-255.	80	80	○	○
	C088	AMI terminal offset tuning	0.-20.0mA	Factory set	Factory set	○	○
	C091	Debug mode enable	00(No display) / 01(Display)	00	00	×	○
	C101	UP/DOWN memory mode selection	00(Clear previous frequency) / 01(Keep previous frequency)	00	00	×	○
Others	C102	Reset mode selection	00(Cancel trip state when reset signal turns ON) / 01(Cancel trip state when reset signal turns OFF) / 02(Cancel trip state when reset signal turns ON(Enable during trip state))	00	00	○	○
	C103	Restart frequency after reset	00(Restart at 0Hz) / 01(Resume operation after frequency matching)	00	00	×	○
	C121	O input zero calibration	0.-9999/1000-6553(10,000-65,530)	Factory set	Factory set	○	○
	C122	O1 input zero calibration	0.-9999/1000-6553(10,000-65,530)	Factory set	Factory set	○	○
	C123	O2 input zero calibration	0.-9999/1000-6553(10,000-65,530)	Factory set	Factory set	○	○

### ● H Group: Motor Constants Functions

H003	Motor capacity	0.20-75.0(kW) [-160(kW)](*)2	Factory set	Factory set	×	×
H203	Motor capacity for second motor	0.20-75.0(kW) [-160(kW)](*)2	Factory set	Factory set	×	×
H004	Motor poles setting	2/4/6/8	4	4	×	×
H204	Motor poles setting for second motor	2/4/6/8	4	4	×	×
H006	Motor stabilization constant	0.-255.	100.	100.	○	○
H206	Motor stabilization constant for second motor	0.-255.	100.	100.	○	○

### ● P Group: Expansion Card Functions

P001	Operation mode on Expansion card 1 error	00(Trip) / 01(Continuous operation)	00	00	×	○
P002	Operation mode on Expansion card 2 error	00(Trip) / 01(Continuous operation)	00	00	×	○
P031	Accel./decel time input selection	00(operation)/01(option1)/02(option2)	00	00	×	×
P044	DeviceNet comm watchdog timer	0.00-99.99s	1.00	1.00	×	×
P045	Inverter action on DeviceNet comm error	00(trip)/01(trip after deceleration stop)/02(Invalid)/03(free-run)/04(deceleration stop)	01	01	×	×
P046	DeviceNet polled I/O:Output instance number	20,21,100	21	21	×	×
P047	DeviceNet polled I/O:Input instance number	70,71,101	71	71	×	×
P048	Input action on DeviceNet idle mode	00(trip)/01(trip after deceleration stop)/02(Invalid)/03(free-run)/04(deceleration stop)	01	01	×	×
P049	Motor poles setting for RPM	0-38(even only)	0	0	×	×
P050	Output frequency on analog reference signal loss	00(Output freq.forced to 0Hz: 500ms wait to recover)/01(Output forced 0Hz: no wait to recover)/02(Output freq.forced to max.freq.A004)/03(Output freq.forced to A020/A220)	00	00	×	×

### ● U Group: User-selectable Menu Functions

U001   U012	User selected functions	no / d001-P002	no	no	×	○
-------------------	-------------------------	----------------	----	----	---	---

(\*1) For UL version only (\*2) 90kW and over